

## CYD1020/CYD1024 HALL-EFFECT SWITCH ICs

CYD1020/CYD1024 Hall-effect switches are monolithic integrated circuits, which are composed of a reverse protector, voltage regulator, Hall voltage generator, differential amplifier, Schmitt trigger and an open-collector output on a single silicon chip. ICs can convert the changeable magnetic field signal into digital voltage output.



### FEATURES

- High Sensitivity
- Resistant to Physical Stress
- Wide Supply Voltage Range
- Interfacing with All Kinds of Logic Circuits

### TYPICAL APPLICATION

- High Sensitive Non-contact Switch
- DC Brushless Motor
- DC Brushless Fan

### FUNCTIONAL BLOCK DIAGRAM

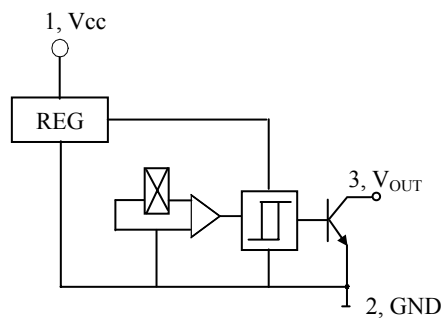

### Magnetic-Electrical Transfer Characteristics

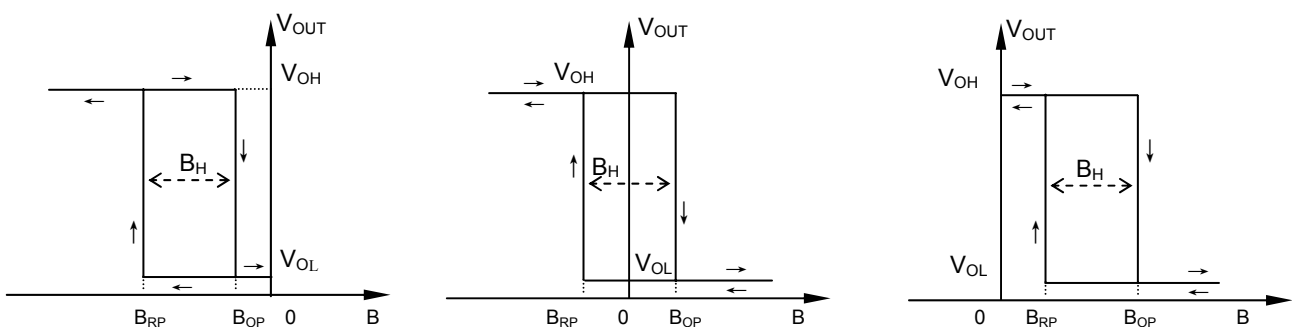

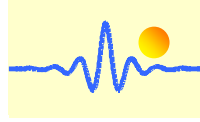

**ABSOLUTE MAXIMUM RATINGS**

Parameter	Symbol	Type	Value		Unit
			Min	Max	
Supply Voltage	V <sub>cc</sub>	CYD1020, CYD1024	4.5	20	V
Magnetic Flux Density	B		unlimited		mT
Output Current	I <sub>o</sub>	CYD1020	-	10	mA
		CYD1024	-	25	
Operating Temperature Range	T <sub>A</sub>	CYD1020, CYD1024	-20	+100	°C
Storage Temperature Range	T <sub>s</sub>		-55	+150	°C

**ELECTRICAL CHARACTERISTICS**

Parameter	Test Condition	Symbol	Value			Unit
			Min	Typ	Max	
Supply Voltage		V <sub>cc</sub>	4.5	-	20.0	V
Output Low Voltage	V <sub>cc</sub> =4.5V V <sub>o</sub> =V <sub>cc</sub> max B=20mT I <sub>o</sub> =5mA I <sub>o</sub> =10mA(CYD1020) I <sub>o</sub> =25mA(CYD1024)	V <sub>OL</sub>	-	0.2	0.4	V
Output Leakage Current	V <sub>o</sub> =V <sub>cc</sub> max, V <sub>cc</sub> open-collector output	I <sub>OH</sub>	-	0.1	10.0	µA
Supply Current	V <sub>cc</sub> =V <sub>cc</sub> max V <sub>o</sub> open-collector output	I <sub>cc</sub>	-	8.0	12.0	mA
Output Rise time	V <sub>cc</sub> =12V C <sub>L</sub> =20pF R <sub>L</sub> =2.4K Ω R <sub>L</sub> =1.2K Ω (CYD1020) R <sub>L</sub> =480K Ω (CYD1024)	t <sub>r</sub>	-	0.3	1.5	µS
Output Fall time		t <sub>f</sub>	-	0.3	1.5	µS

**Magnetic Characteristics (Unit: mT)**

Parameter	Rank	Value			Unit
		Min	Typ	Max	
Operate Point (B <sub>OP</sub> )	A <sub>11</sub>	-	-	8	mT
	A <sub>12</sub>	-	-	10	
	A <sub>2</sub>	-	-	15	
	B	-	-	20	
Release Point (B <sub>RP</sub> )	A <sub>11</sub>	-8	-	-	mT
	A <sub>12</sub>	-10	-	-	
	A <sub>2</sub>	-15	-	-	
	B	-20	-	-	
Hysteresis (B <sub>H</sub> )		2	6	-	

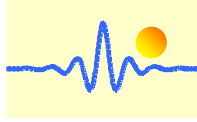

## Characteristics Curves

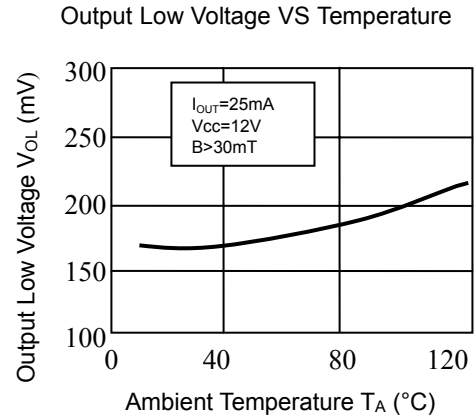
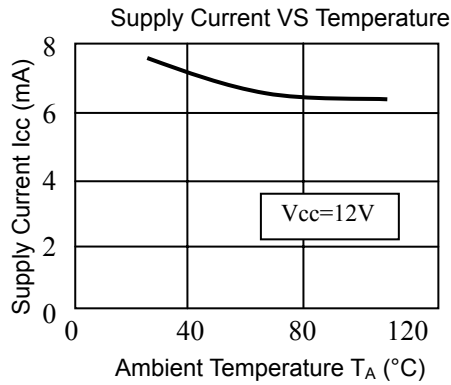

B<sub>OP</sub> and B<sub>RP</sub> VS Temperature

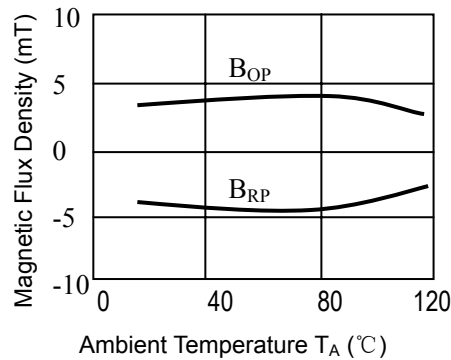

## Package (Unit: mm)

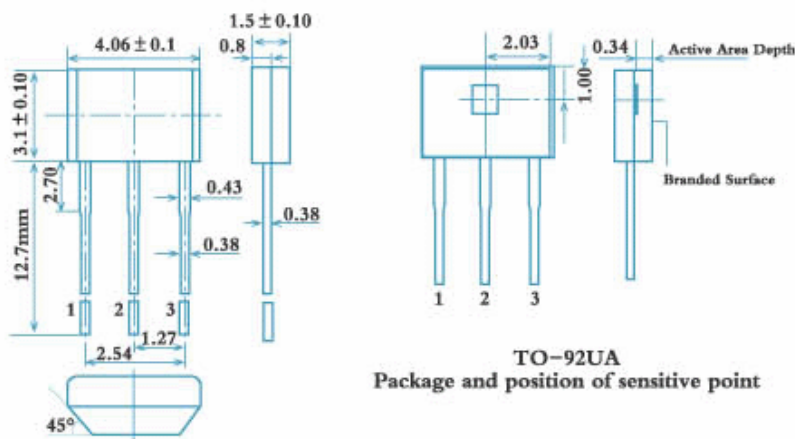

### PIN NOTES

1. Power Supply
2. Ground
3. Output

### CAUTIONS

- ◆ It is possible that outside mechanical stress affects the operating point and the release point of Hall-effect circuits, therefore, mechanical stress should be lessened as far as possible in the process of assembly;
- ◆ Pay attention to the soldering temperature at the leads, keep it lower in a short time to guarantee good soldering quality.